

Leak KNX Leakage Sensor for water and pipe breakage reporting

Technical specifications and installation instructions

Item number 70314



1. Description

The **Leakage sensor Leak KNX** includes an evaluation unit and a probe. If there is water between the electrodes of the probe, the evaluation unit produces an acoustic alarm. Additionally, the alarm signal is sent to the KNX bus.

Functions:

- Detection of water on the probe
- Acoustic alarm signal by the evaluation unit during a water alarm (sustained beeping tone). Short beeping during the follow-up time (1 minute after the end of the alarm).
- Alarm signal sent to the KNX bus with a text message
- 4 AND and 4 OR logic gates with each 4 inputs. Every switching incident as well as 16 logic inputs in the form of communication objects, may be used as inputs for the logic gates. The output of each gate may optionally be configured as 1 bit or 2 x 8 bits

Configuration is made using the KNX software ETS 5. The **product file** can be downloaded from the ETS online catalogue and the Elsner Elektronik website on www.elsner-elektronik.de in the "Service" menu.

1.1. Deliverables

- Evaluation unit
- Probe with BNC cable
- Stainless steel plumbing screw 4.5 x 70 (DIN 7995), matching dowel SX6 x 30

1.2. Technical specifications

1.2.1. Analysis unit

Casing	Plastic
Colour	Grey
Installation	Surface mounted
Protection category	IP 20
Dimensions	approx. 105 x 105 x 65 (W x H x D, mm),
Weight	approx. 180 g
Ambient temperature	Operation -20...+70°C, storage -55...+90°C.
Ambient humidity	max. 95 % RH, avoid condensation
Auxiliary voltage	24 V DC
Power on the bus	10 mA
Data output	KNX +/- Bus connector terminal
BCU type	unit's own microcontroller
PEI type	0
Group addresses	254
Assignments	254
Communication objects	54
Current Consumption	at 24 V DC ±10% no alarm: max. 15 mA alarm: max. 30 mA
Probe input	1 x electrode probe, plug-in BNC terminal

The product is compliant with the provisions of EC guidelines.

1.2.2. Probe

Casing	Polished stainless steel
Installation	for placing on the floor
Protection category	IP 68
Electrode chemical resistance	Water
Dimensions	Diameter: approx. 77 mm Height: approx. 33 mm
Cable length	approx. 140 mm (plus cable grip and plugs). Extendable to 10 m.
Weight	approx. 200 g
Ambient temperature	Operation -25...+85°C, storage -40...+125°C.

The product is compliant with the provisions of EC guidelines.

2. Installation and commissioning

2.1. Installation notes

Installation, testing, operational start-up and troubleshooting should only be performed by an electrician.

CAUTION! Live voltage!

- There are unprotected live components inside the device.
- National legal regulations are to be followed.
 - Ensure that all lines to be assembled are free of voltage and take precautions against accidental switching on.
 - Do not use the device if it is damaged.
 - Take the device or system out of service and secure it against unintentional use, if it can be assumed, that risk-free operation is no longer guaranteed.

The device is only to be used for its intended purpose. Any improper modification or failure to follow the operating instructions voids any and all warranty and guarantee claims.

After unpacking the device, check it immediately for possible mechanical damage. If it has been damaged in transport, inform the supplier immediately.

The device may only be used as a fixed-site installation; that means only when assembled and after conclusion of all installation and operational start-up tasks and only in the surroundings designated for it.

Elsner Elektronik is not liable for any changes in norms and standards which may occur after publication of these operating instructions.

2.2. Evaluation unit installation

The evaluation unit may only be installed and operated in dry, indoor spaces.

Never expose the evaluation unit to water (e.g. rain) or dust. This can damage the electronics.

The evaluation unit can be screwed to the wall with mounting brackets.

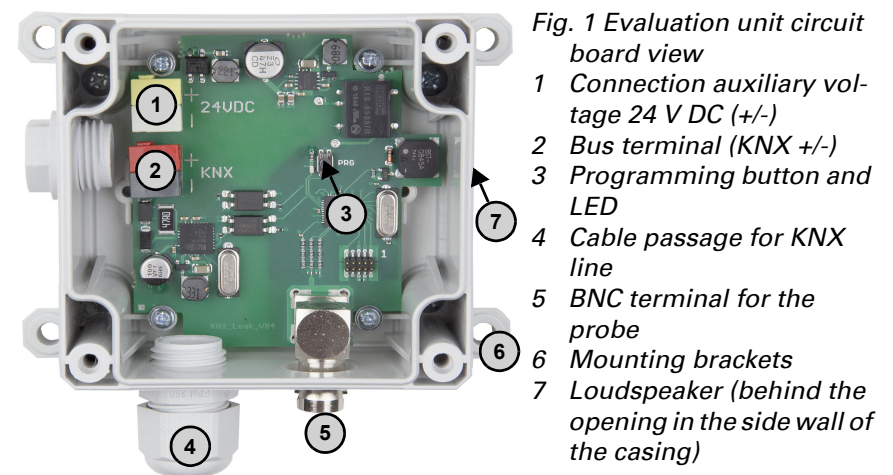

2.3. Probe placement

The electrode probe is placed on the floor with the contacts facing downwards. To prevent slipping or tilting, the probe can be screwed to the floor.

Ideally, the probe should be located in a place that, in case of water damage, would be the first to be flooded – e.g. close to washing machines, sinks, baths, water pipes or pump sumps.

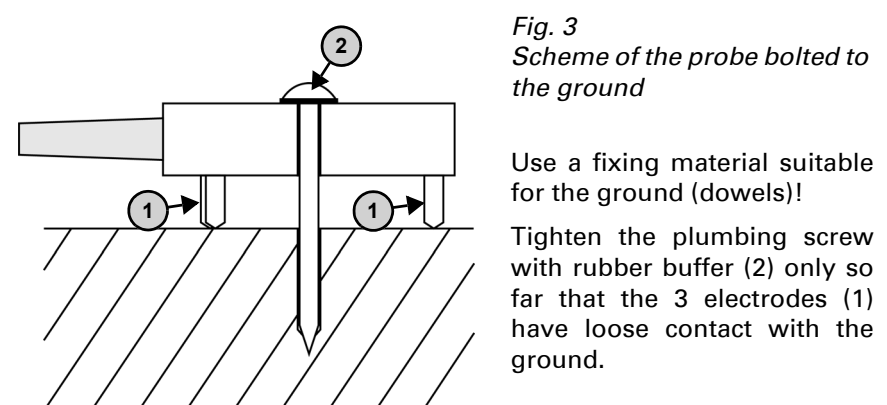
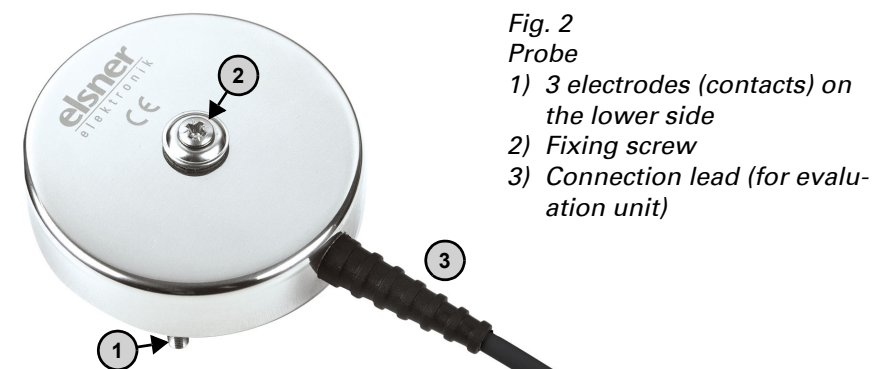

2.4. Leakage sensor commissioning

Fig. 4 Overview

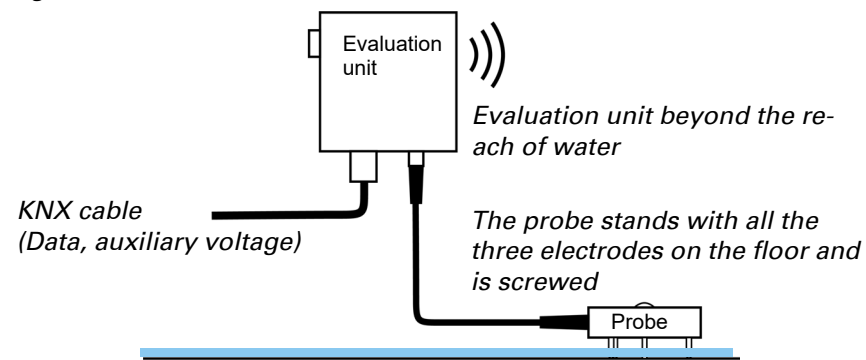

1. Connect the probe to the evaluation unit (insert the BNC plug).
2. Connect the bus lead +/- (black/red plug) and the auxiliary voltage +/- (white/yellow plug) to the provided terminals on the circuit board of the device.
3. Address the device (see *Addressing the device*) and configure the ETS.

2.5. Bus settings

If there is water contact, the evaluation unit submits an acoustical signal and sends an alarm signal and a text message to the KNX bus. Adjust the setting for these parameters in the ETS.

3. Addressing the device

The device is delivered with the bus address 15.15.255. You can program a different address in the ETS by overwriting the address 15.15.255 or by teaching the device via the programming button.

The programming button is inside the case (Fig. 1: No. 3).